

CONFIDENTIAL AND PROPRIETARY TO KZVALVE, LLC. UNAUTHORIZED USE, DISCLOSURE OR REPRODUCTION IS PROHIBITED

CUSTOMER REVISIONS			
REV	ECN	CHANGE	MODIFIED BY
1	24-0679	RELEASE TO PRODUCTION	Benjamin Klinkebiel

PART NUMBER: 23CA9-1CEFS-D01

CUSTOMER: KZVALVE

ACTUATOR DESIGN NOTES:

1. KZVALVE SERIES: EH6
2. BODY MATERIALS: GF NYLON
3. LED INDICATOR: STANDARD
4. GASKET: SILICONE
5. MOTOR SHAFT GROMMET MATERIAL: FLUOROCARBON
6. RESPONSE TIME: 0.5S@12VDC FOR 90 DEGREE TRAVEL
7. AMBIENT STORAGE TEMPERATURE: -67°F TO 221°F (-55°C TO 105°C)
8. AMBIENT OPERATING TEMPERATURE: -40°F TO 185°F (-40°C TO 85°C)
9. ENCLOSURE RATING: NEMA 6P PER NEMA 250 & IP69K PER ISO 20653 & IEC 60529
10. ELECTRICAL:
 1. OPERATING INPUT VOLTAGE: 9VDC TO 32VDC
 2. CURRENT DRAW
 1. NORMAL OPERATION: 1.0-1.5 AMPS@12VDC
 2. CONTINUOUS (IDLE STATE): 0.04 AMPS
 3. STALL (LOCKED ROTOR): 3.0 AMPS@12VDC
 3. CONNECTION: MOLDED DEUTSCH RECEPTACLE
 1. TERMINALS:
 1. PIN 1: GND
 2. PIN 2: (+) FEEDBACK @CLOSED
 3. PIN 3: (+) SIGNAL TO OPEN
 4. PIN 4: (+) POWER IN 12VDC

VALVE DESIGN NOTES:

11. KZVALVE SERIES: TX2
12. BODY MATERIALS: GF POLYPROPYLENE
13. WETTED MATERIALS: GF POLYPROPYLENE/316 SS
14. O-RING MATERIAL: EPDM
15. STEM SEAL MATERIAL: FLUOROCARBON
16. SEAT MATERIAL: CG FILLED TEFLON
17. PORT CONNECTIONS
 1. PORT 1: M100 FLANGE
 2. PORT 2: M100 FLANGE
 3. PORT 3: QD
 4. PORT 4: CAPPED QD
18. FUNCTIONAL STATES
 1. DEFAULT STATE: 0°
 - A. PORT 1: OPEN
 - B. PORT 2: OPEN
 - C. PORT 3: CLOSED
 - D. PORT 4: CLOSED
 2. ACTUATED STATE: 90°
 - A. PORT 1: OPEN
 - B. PORT 2: OPEN
 - C. PORT 3: OPEN
 - D. PORT 4: CLOSED
19. MAXIMUM PRESSURE DIFFERENTIAL: 150 PSI @ 70 F
20. MAXIMUM BODY PRESSURE: 150 PSI @ 70 F

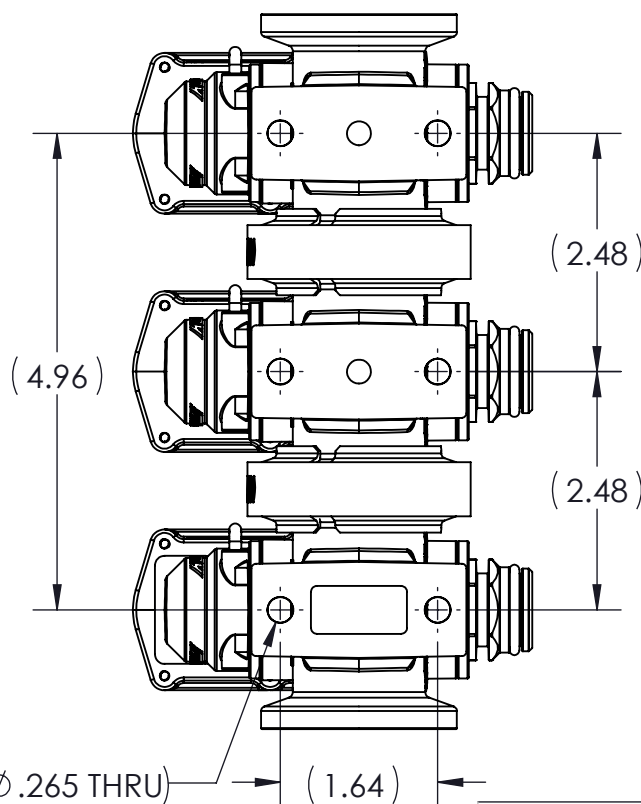
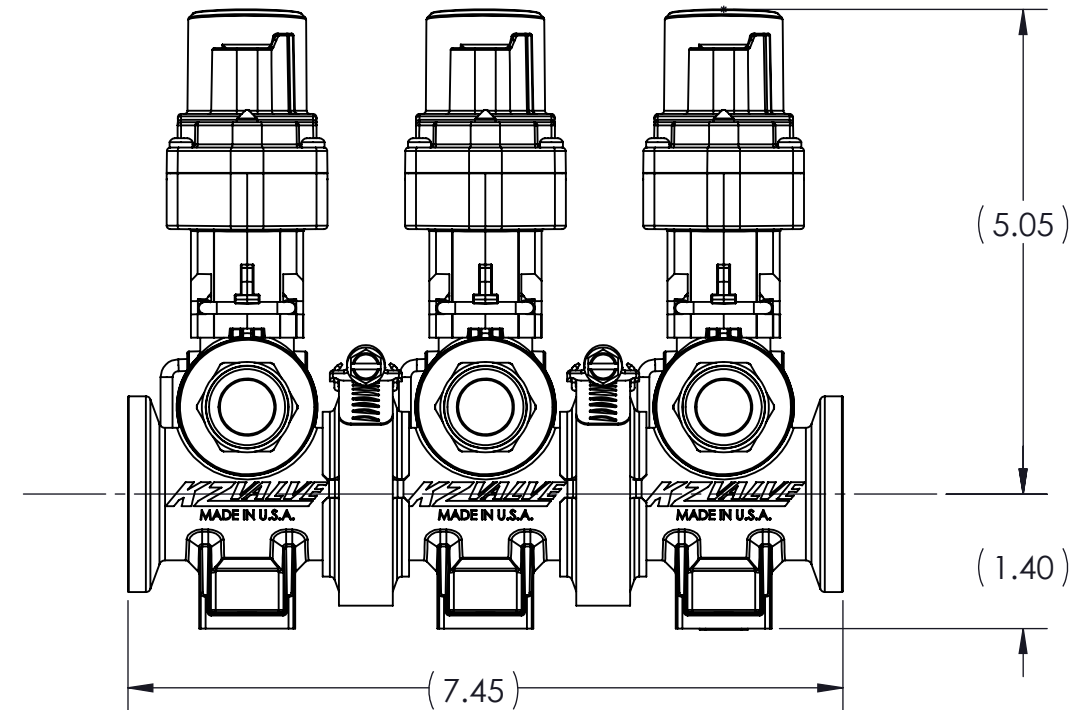
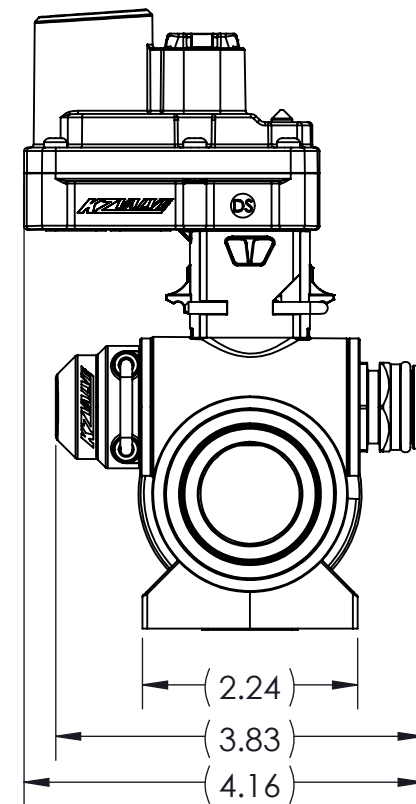

CONFORMS TO ASME STANDARDS Y14.5-2009
 DENSITY: 0.042 LBM/CU IN
 MASS: 1.580 LBM
 SURF AREA: 773.298 SQ IN
 VOLUME: 37.448 CU IN

DESIGNED BY: Benjamin Klinkebiel
 DRAWN BY: Benjamin Klinkebiel
 APPROVED:
 SCALE: 1:1
 SIZE: B
 MATERIAL: AS NOTED

KZVALVE
 23860 K2 PARKWAY
 GREENWOOD, NE 68366 USA
 PHONE: +1.402.944.2767
 FAX: +1.402.944.2402

TITLE: ACTUATED MANIFOLD, EH6, TX2, 3-WAY BL DIVERter, 3-SECT, 0.5S@12/24VDC

PART NO: 23CA9-1CEFS-D01	REV: 1
DRAWING NO: 23CA9-1CEFS-D01	SHEET: 3 OF 3